



Suniva OPTIMUS Installation and Instruction Manual

Introduction

This manual provides safety and installation instructions for Suniva photovoltaic modules, herein referred to as module(s), with the following model numbers:

- OPTXXX-72-4-YYY; Where XXX could be 285 to 330 in increments of 5. YYY could be either 100, 101, 1B0, or 1B1
- OPTXXX-60-4-YYY; Where XXX could be 235 to 270 in increments of 5. YYY could be either 100, 101, 1B0 or 1B1

To maintain the safety of yourself and others, carefully read the entire installation and instruction sheet prior to installation and operation. System safety and proper design should be ensured by qualified personnel. Failure to comply with these instructions will invalidate the Suniva Limited Warranty for the module. For more information, please visit our website.

Safety

- Suniva modules produce electricity when exposed to light. To avoid electric shock and injury, completely cover the front of the module with an opaque material before making any electrical connections and disconnect the module from all electrical connections before any maintenance or cleaning.
- Only individuals trained in the principles of electricity and electrical equipment should install modules.
- Modules must be installed in a manner compliant with the National Electric Code (NEC) and/or all applicable standards and codes.
- Use properly insulated tools and appropriate protective equipment and work only in dry conditions.
- Protective gloves should be worn when handling modules to protect against sharp edges and burns.
- Do not artificially concentrate sunlight on the module(s).
- Do not install the modules in an area where flammable gas or material may be present.
- Do not remove any part installed by a qualified installer, or disassemble the module in any way.
- Use original packaging to transport and store module.
- Avoid excessive loads, bending, and twisting of the module.
- Do not step/stand on the module.
- Avoid wearing metallic jewelry when installing or handling the module to protect against electric shock.
- Do not leave the module unsupported or loosely fixed during or prior to installation and avoid installing during heavy winds.
- Do not attempt to repair a broken or damaged module, replace immediately to avoid fire danger and shock hazard. Use caution when handling as damaged modules may conduct electricity to the frame.

Product Information

- This solar module can be used in series and parallel array configurations or as a stand-alone system.
- For IEC installations: This module is certified to IEC 61730-1 and IEC 61730-2 for application Class A and is rated for use in systems operating at voltages greater than 50 VDC or 240 W, where general contact access is expected. And for Class A applications this module meets requirements of Safety Class II as defined by IEC 61140.
- The allowable operating temperatures range of the module is 185 °F to -40 °F (85 °C to -40 °C).

Serial Number

- The structure of the module serial number provides the following information:
 Example: SJWSH00011103310017
 S-JWSH-0001 – 11– 03 – 31 - 0017
 A-BBCC-DDDD-EE-FF-GG-HHHH
 A: Manufacturer; BB: Factory; CC: Factory Location
 DDDD: Engineering Number; EE: Year of Production; FF: Month of Production; GG: Date of Production; HHHH: 4 digit sequence 0 to 9999 for sequential production starting on each new day of production at 0001.

Electrical Characteristics

- See tables at end of installation manual for electrical parameters.
- The electrical characteristics are within ± 10 percent of the indicated values of I_{SC} , V_{OC} , and P_{MAX} under standard test conditions; irradiance of 100 mW/cm², AM 1.5 spectrum, and a cell temperature of 25 °C (77 °F).
- Maximum series fuse rating is 15 A
- This module is rated for use in systems of up to 1000 V for TUV/IEC and up to 1000 V for UL
- Under normal conditions, a photovoltaic module is likely to experience conditions that produce more current and/or voltage than reported at standard test conditions. Accordingly, the values of I_{SC} and V_{OC} marked on this module should be multiplied by a factor of 1.25 when determining component voltage ratings, conductor ampacities, fuse sizes, and size of controls connected to the PV output.
- Per NEC: "Refer to Section 690-8 of the NEC for an additional multiplying factor of 125 percent (80 percent derating) which may be applicable."

Temperature Coefficients

Temperature Coefficients		
Power	$\gamma, P_{max} (\%/^{\circ}C)$	- 0.420
Voltage	$\beta, V_{oc} (\%/^{\circ}C)$	- 0.335
Current	$\alpha, I_{sc} (\%/^{\circ}C)$	+ 0.047
NOCT	C	46 +/- 2

Mounting Overview

- Mounting design and installation should be performed by trained professional and must conform to local codes.
- Select a site and configuration that maximizes direct sunlight exposure and eliminates or minimizes shadowing.
- Avoid small tilt angles to prevent the accumulation of dirt/debris along module edge.
- Improper mounting of the module(s) can lead to damage or injury and will void the warranty. Do not drill additional mounting holes into module frames. This will void the warranty.
- The module(s) should be fixed in a manner that withstands all expected loads, including those caused by wind, snow and ice. Verify by certified engineer.
- Orient the module junction box in such a way and provide clearance between the module frame and mounting surface to ensure that water cannot build up at the junction box and so the junction box does not contact the mounting surface.
- The module has a Class C Fire Rating and must be installed on a roof with appropriate fire resistance. The fire rating of this module is valid only when mounted in the manner specified in the mechanical mounting instructions.
- If the module is to be mounted to a roof of a building, the assembly must be mounted over a fire resistant roof covering suitable for the application. A slope less than 5 in/ft (127 mm/305mm) is required to maintain the fire class rating.

Mounting Instructions

- It is acceptable to mount this module using bolts or clamps to secure module to a structure on a roof, building or ground.
- The module is considered to be in compliance with UL 1703 only when the module is mounted in the manner specified by the mounting instructions below.
- If mounting module in landscape orientation please ensure cable length is of appropriate length for interconnection.
- Provide a minimum of 4 in. (~100 mm) clearance between back of module and roof or ground or building, etc. when installing to ensure proper air flow.
- Allow for thermal expansion of the frames by providing a minimum of 0.25 in. (or approximately 6 mm) spacing between modules.
- OPTXXX-60-4-1YY Series modules are rated to 5400 Pa or 2400 IEC Positive Static Load and 2400 Pa IEC61215 Negative Load when mounted according to these instructions. Read the module label to determine load rating.
- OPTXXX-72-4-1YY Series modules are rated to 2400 Pa IEC61215 Positive and Negative Load when mounted according to these instructions.
- Both OPTXXX-60-4-1YY and OPTXXX-72-4-1YY are rated to UL1703 design load rating of 30 lb/ft².
- Any alternative configurations must be verified to meet load requirements.

Rail Mounting

- A supporting structure can be used to mount the modules at various tilt angles. See Figure 1 for recommend configuration. Ensure no dissimilar combinations of metals be used that when damp or wet could result in degradation of the materials and as a result create conditions that prevent the module from meeting installation requirements and instructions set forth in this manual.
- The frame of each module has four mounting holes. These are to be used to secure the module(s) to the supporting structure. Use ¼ in. (or M6) bolt with a ¼ in. (or M6) flat washer beneath bolt head and a ¼ in. (or M6) lock washers between ¼ in. (or M6) nut and rail with a minimum of 80 in-lb (9 N-m) of torque to secure bolt. Use only stainless steel mounting hardware.
- It is recommended that the mounting rails must be aligned with the frame mounting holes (Figure 1) and run perpendicular to the length of the module.

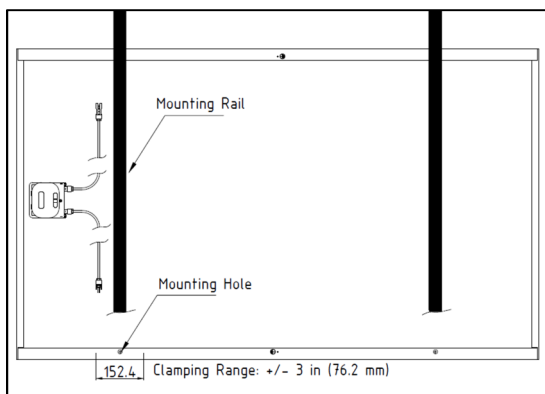

Figure 1: Mounting Hole Location and Example of Rail Mount

Clamp Mounting

- Clamps can be used to achieve mounting to a support structure. A minimum of four points of contact at the location (+/- 3 in. or 76.2 mm) of pre-drilled mounting holes should be used. See Figure 2 for typical clamp assembly.

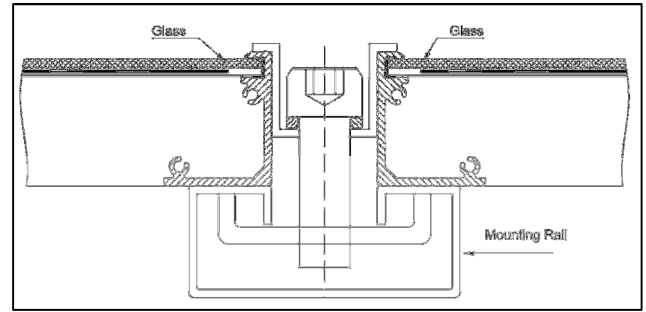



Figure 2: Clamp Mounting Example Diagram

Equipment Grounding

- A module with exposed conductive parts is considered to be in compliance with UL 1703 only when it is electrically grounded in accordance with the instructions presented below and the requirements of the National Electrical Code (NEC)
- Where common grounding hardware (nuts, bolts, star washers, split-ring lock washers, flat washers and the like) is used to attach a listed grounding/bonding device, the attachment must be made in conformance with the grounding device manufacturer's instructions.
- Common hardware items such as nuts, bolts, star washers, lock washers and the like have not been evaluated for electrical conductivity or for use as grounding devices and should be used only for maintaining mechanical connections and holding electrical grounding devices in the proper position for electrical conductivity. Such devices, where supplied with the module and evaluated through the requirements in UL 1703, may be used for grounding connections in accordance with the instructions provided with the module.
- Ground the module in accordance with local requirements and NEC Article 250 where applicable. Size and earth ground conductor accordingly.
- Earth conductors should be large enough for let-through energy.
- Methods to secure earth wires to PV module frame should be mechanically sound to ensure electrical continuity at all times.
- When using a self-tapping screw to make bonding connection ensure at least two full threads engage in the metal.
- Do NOT use bare copper grounding lug.
- The following methods are certified for grounding the module.
- For Canada; Grounding method must comply with Safety Standard for Electrical Installations, Canadian Electrical Code, Part 1. CSA C22.1
- When using provided grounding holes on module frame locate 4.2 +/- 0.2 mm diameter grounding holes shown in

Figure 3 that are marked by the grounding symbol. . The flange on which the grounding hole is located

Grounding using Screw and Washer Assembly

Attach the grounding conductor to the module frame through at least one of the two grounding holes, See Figure 3.

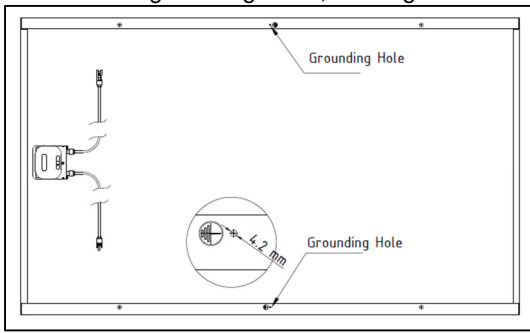

Figure 3: Grounding Hole Location

Wrap an un-insulated portion of 10 to 12 AWG copper grounding wire around the grounding screw between two 0.2"ID x 0.394"OD x 0.030" (5 x 10 x 1 mm) stainless steel flat washers, ensuring any exposure part of the wire is covered by insulation. Connect the provided #10-32 x 0.5 in (12.7 mm) stainless steel screw and flat washers to the grounding hole. Use a flat head screwdriver to tighten them applying a torque of 18 in-lb (2 N-m). Flat washer should be cupped side in towards the grounding wire. To avoid corrosion of dissimilar metals ensure washer is between grounding wire and aluminum frame. See Figure 4

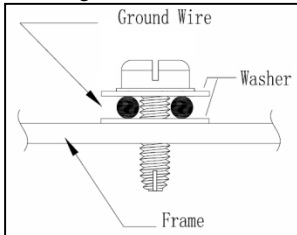

Figure 4: Grounding with #10-32 Screw

(Or) Use of Tyco SolKlip Grounding Clip Assembly

The grounding clip manufactured by Tyco Electronics Corp. (Part number: 1954381-1) is UL listed and designed for module grounding applications using a solid 10 to 12 AWG un-insulated ground wire. It is attached to grounding hole on module frame, Figure 3, by an integrated, 10-32 in. self-tapping screw. Place the grounding clip onto the frame, making sure that the screw straddles the grounding hole. Using a No. 2 cross-recessed screwdriver, thread the screw into the hole until the head is flush with the base and the base is flush with the frame, then tighten the screw with another 1/4 to 1/2 turn. Recommended torque is between 20 in-lb (2.3 N-m) for screw. Insert the wire into the wire slot. Press down on both ends of the wire (the wire slot will cause the wire to form a slight curve). Manually, or using channel lock pliers, push the slider over the base until it covers the base. This will terminate the wire.

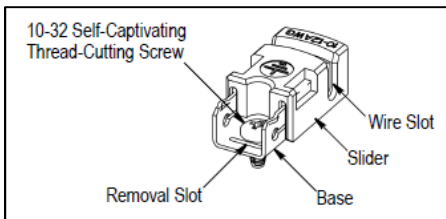

Figure 5: SolKlip Grounding Diagram

(Or) Use of Tyco Solklamp Grounding Bolt Assembly

The grounding bolt manufactured by Tyco Electronics Corp. (Part number: 2058791-1) is UL listed and designed for module

grounding applications using a solid 6 to 12 AWG un-insulated ground wire. It is attached to grounding hole on module frame, Figure 3, by an integrated, 8-32 in threaded post and nut. Locate the grounding hole on the underside of the module frame (1). Insert the threaded post end of the wire bolt into the hole (2). Finger-tighten the hex washer nut onto the threaded post (3). Position the grounding wire into the wire slot (4). Finger-tighten the nut onto the wire slot end until wire is compressed (5). Using a 9/16" open end wrench to hold the hex body of the wire bolt, and using a 9/16" socket wrench, tighten the mounting hex washer nut (3) to a torque of 25 in-lb (2.82 N-m). While holding the hex body, use an 11-32" socket wrench to tighten the wire binding hex nut (5) to a torque of 45 in-lb (5.08 N-m). See Figure 6.

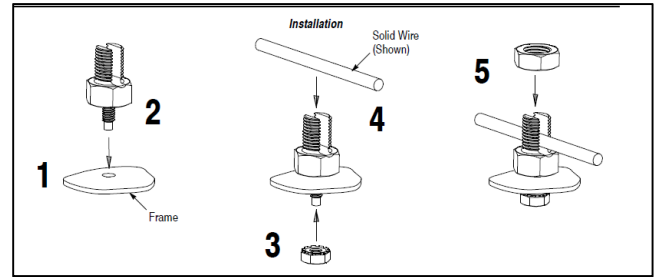

Figure 6: Solklamp Grounding Bolt Diagram

(Or) Use of Self Tapping Grounding Lug

The grounding bolt manufactured by IlSCO (Part number: GBL-4DBT) and bolt manufactured by Burndy (Part number: CL501TN) are UL listed and designed for module grounding applications using a solid 4 to 14 AWG un-insulated ground wire. Locate module grounding hole, Figure 3. Assemble a #10 stainless steel star washer (1) and #10-32 self-tapping screw (2) through grounding lug (1) and into the module grounding hole until washer and lug are flush with frame as shown in Figure 7. Using a 5/16 in. open ended wrench to tighten the screw (2) another 1/4 to 1/2 turn with recommended torque between 20 and 25 in-lb (2.3 and 2.8 N-m). Insert grounding wire into conductor slot of lug and tighten threaded set screw using a 5.5 x 0.8 mm (3/16 x 0.025 in.) flat headed driver to the torque specified in Table 1 to compress the conductor.

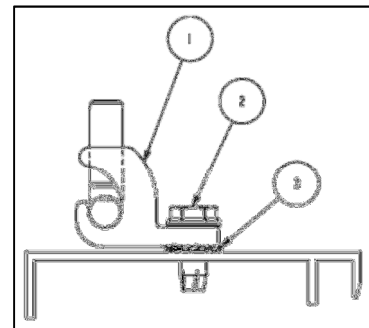

Figure 7: Self Threaded Grounding Lug: Grounding Diagram

Tightening Torque Guide for Conductor (#14 - #4 Cu Only)	
Conductor Size	Tightening Torque
#14 - #10	35 in-lb (4.0 N-m)
#8	40 in-lb (4.5 N-m)
#6 - #4	45 in-lb (4.1 N-m)

Table 1: Torque Guide for Conductor in Grounding Lug

(Or) Use of Grounding Lug with Nut

The grounding bolt manufactured by Burndy (Part number: CL501TN) is UL listed and designed for module grounding applications using a solid 4 to 14 AWG un-insulated ground wire. Locate module grounding hole, Figure 3. Using a 5/16 open ended wrench, thread #10-32 self-threading screw through the grounding hole to open up the hole size and remove. Assemble a #10-32 bolt (2) through the grounding lug (1) and into the module grounding hole. Install a # 10 stainless steel star washer (3) and hex nut (4) around the frame until washer and lug are flush with frame, as shown in figure 8. Using two 5/16 in. open ended wrenches to tighten the screw (2) and bolt (4) another ¼ to ½ turn with recommended torque between 20 and 25 in-lb (2.3 and 2.8 N-m). Insert grounding wire into conductor slot of lug and tighten threaded set screw using a 5.5 x 0.8 mm (3/16 x 0.025 in.) flat headed driver to the torque specified in Table 1 to compress the conductor.

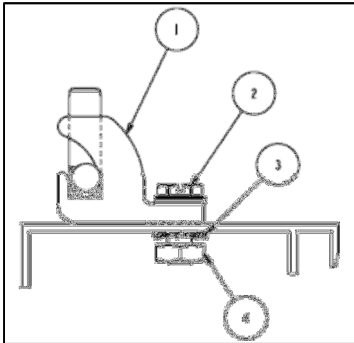

Figure 8: Grounding Lug with Nut: Grounding Diagram

(Or) Use of WEEBs and Associated Racking

Cat. No.	Racking System	Torque
WEEB-DMC	DP&W Power Rail	10 ft-lb (13.5 N-m)
WEEB-PMC	SnapNrack	15 ft-lb (20 N-m)

Table 2: WEEB and Racking Guide

Listed WEEB devices intended for use in bonding PV modules to mounting structures may be used for grounding as described in the NEC or CEC accordingly. Prior to installation, all bolts that employ bonding and grounding hardware shall have general purpose anti-seize applied onto the bolt threads. Install the WEEB onto the midclamp of racking hardware to bond PV module frames to mounting rail in accordance with the layout specified in the Burndy installation manual for the pertinent racking systems. Pre-assemble WEEB-DMC on to PD&W midclamp assembly as showing in Figure 9. Pre-assemble WEEB-PMC onto SnapNRack midclamp assembly as shown in Figure 10. Ensure both sides of the modules are positioned against midclamp and WEEB teeth are underneath module frames. Hand tighten fasteners to keep modules in place since WEEBs are intended for one time use only and cannot be reused. When position is finalized, tighten hardware to torque specified in Table 2. Using the approved hardware, install the WEEB Lug at the end of each rail to connect the equipment ground conductor to the system. Each nut/bolt combination that installs a Lug and Bonding Jumper shall be tightened to the torque specified in the Burndy manual. Lug is capable of securing one 6 AWG or two 10/12 AWG copper conductors. Tighten bolt securing copper conductor to 7 ft-lb

(10 N-m) torque. For WEEB details, refer to the Burndy Installation Manual.

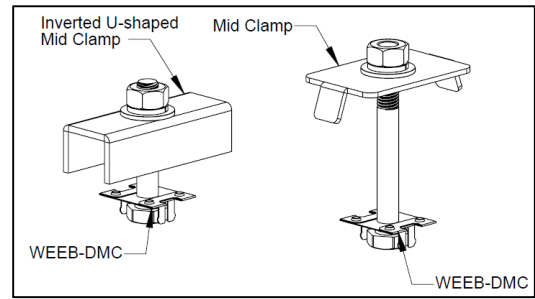

Figure 9: WEEB-DMC Assembly

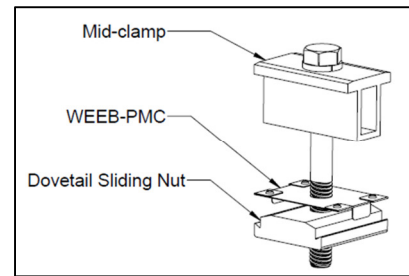

Figure 10: WEEB-PMC Assembly

Wiring

- Connect modules using the supplied connectors in series or parallel configurations according to the “+” positive or “-”negative.
- Use only same type of connector, to ensure the reliability of the electrical connection.
- For conductor utilize suitable “Wet or Dry” type sunlight resistant cable (PV-Wire, or USE-2 type) with temperature rating of 90 °C or higher and sized 12 AWG or larger. Paralleled configurations may require greater wire size to accommodate increase current. Ensuring proper conductor sizing is the responsibility of the installer.
- Maintain a minimum bending radius of 50 mm at all locations along the cable. Pay particular attention to the exit point from the junction box and interconnection point between modules.

Junction Box

- Do not open the junction box or change inter-module wiring. All wiring connections are made in the factory and doing so may void the warranty.
- Verify junction box lid is firmly closed when installing panel.
- Do not alter the connectors. Doing so will void the warranty.

Bypass Diodes

- 3 Schottky type bypass diodes are pre-assembled in each module in parallel with cell strings.
- Do not uninstall these diodes.
- Bypass Diode Ratings: V_{RRM} : 40 V, I_{FAV} : 16 A @75 °C or V_{RRM} : 40 V, I_{FAV} : 20 A @ 95 °C

Series/Parallel Configurations

- Series or Parallel configurations must be restricted to a maximum system voltage of 1000 VDC (UL) or 1000 VDC (IEC).
- Voltage and current are temperature dependent and systems should be designed to allow for variations due to local conditions.
- The voltage of modules in series connections will be equal to the sum of the individual voltages.
- The current of modules in parallel connections will be equal

to the sum of the individual currents.

- Refer to the electrical characteristics for the values of I_{sc} and V_{oc} .

Series and Parallel interconnection restrictions

- At standard conditions (AM1.5G, 25 °C) the number of allowable modules in series is equal to the maximum system voltage divided by the Open Circuit voltage. The number of modules in series should be constrained by the expected minimum ambient temperature, module V_{oc} temperature coefficient (β), and module V_{oc} . Suniva recommends the following to allow for a minimum ambient temperature of -40 C.

To prevent an open circuit voltage in excess of 1000 V:

For OPTXXX-60 Series modules: 21

For OPTXXX-72 Series modules: 17

To prevent an open circuit voltage in excess of 600 V:

For OPTXXX-60 Series modules: 12

For OPTXXX-72 Series modules: 10

- Overcurrent protection (such as fuses) must be used when connecting three (3) or more strings in parallel.

Over Current Protection

- Series or parallel connections of modules or strings must be provided adequate over current protection such as a recognized circuit breaker or fuse meeting minimum requirements listed in the Product Information section of this manual and be certified and properly rated. System design and protection for any series/parallel configuration must be verified by a certified engineer and is the responsibility of the system integrator as currents may exceed 1.25 times I_{sc} under some conditions.

Disconnection Under Load

- Do NOT disconnect or connect module under load.
- Modules will produce electricity even under low light conditions. Treat modules as if they are live electrical equipment.
- To avoid electric shock and injury, completely cover the front of the module with an opaque material and disconnect the module from all electrical connections before disconnecting or connecting module wiring.

Maintenance

Maintenance is recommended to ensure optimal performance:

- Depending on local conditions, periodically inspect and clean the surface of the module with water and a soft cloth or sponge when the modules surface becomes dirty and rain water is insufficient to remove dirt/debris.
- Never clean the modules during the middles of the day when the glass is hot to avoid injury.
- Never scratch or rub away any dirt when the modules are dry.
- Check the electrical and mechanical connections annually to ensure all the connections are secure, tight, clean and free of corrosion.

Disclaimer of Liability

Suniva does not assume responsibility and expressly disclaims liability for loss, damage or expense arising out in any way connected with installation, operation, use or maintenance by using this manual. Suniva assumes no responsibility for any infringement of patents or other rights of third parties that may result from use of the module. No license is granted by implication or otherwise under any patent or patent rights. Suniva reserves the right to make changes to the product, specifications or this manual without prior notice.

Electrical Characteristics by Module Type

For OPTXXX-60 Series modules ending in 100

Module ID	P_{MP} [W]	V_{OC} [V]	I_{SC} [A]	V_{MP} [V]	I_{MP} [A]
OPT240-60-4-1YY	240	37.2	8.84	28.9	8.30
OPT245-60-4-1YY	245	37.5	8.89	29.4	8.35
OPT250-60-4-1YY	250	37.7	8.98	29.6	8.44
OPT255-60-4-1YY	255	37.9	9.05	30.0	8.50
OPT260-60-4-1YY	260	38.1	9.08	30.2	8.60
OPT265-60-4-1YY	265	38.3	9.12	30.7	8.64
OPT270-60-4-1YY	270	38.5	9.15	31.2	8.68
OPT275-60-4-1YY	275	38.6	9.25	31.5	8.74

For OPTXXX-60 Series modules ending in 101, 1B0 or 1B1

Module ID	P_{MP} [W]	V_{OC} [V]	I_{SC} [A]	V_{MP} [V]	I_{MP} [A]
OPT235-60-4-1YY	235	37.1	8.73	28.7	8.18
OPT240-60-4-1YY	240	37.3	8.76	29.2	8.23
OPT245-60-4-1YY	245	37.6	8.84	29.5	8.30
OPT250-60-4-1YY	250	37.8	8.90	30.0	8.34
OPT255-60-4-1YY	255	38.1	8.96	30.2	8.45
OPT260-60-4-1YY	260	38.3	9.01	30.5	8.52
OPT265-60-4-1YY	265	38.3	9.12	30.7	8.64
OPT270-60-4-1YY	270	38.5	9.14	31.0	8.70
OPT275-60-4-1YY	275	38.6	9.28	31.5	8.74
OPT280-60-4-100	280	38.7	9.3	31.7	8.84

For OPTXXX-72 Series modules ending in 100

Module ID	P_{MP} [W]	V_{OC} [V]	I_{SC} [A]	V_{MP} [V]	I_{MP} [A]
OPT290-72-4-100	290	45.0	8.76	35.2	8.23
OPT295-72-4-100	295	45.2	8.84	35.5	8.30
OPT300-72-4-100	300	45.5	8.90	36.0	8.34
OPT305-72-4-100	305	45.6	9.00	36.1	8.45
OPT310-72-4-100	310	45.7	9.06	36.2	8.56
OPT315-72-4-100	315	45.9	9.10	36.5	8.62
OPT320-72-4-100	320	46.1	9.20	36.8	8.69
OPT325-72-4-100	325	46.3	9.27	37.0	8.77
OPT330-72-4-100	330	46.5	9.30	37.5	8.80

For OPTXXX-72 Series modules ending in 101, 1B0 or 1B1

Module ID	P_{MP} [W]	V_{OC} [V]	I_{SC} [A]	V_{MP} [V]	I_{MP} [A]
OPT285-72-4-1YY	285	44.9	8.64	35.1	8.12
OPT290-72-4-1YY	290	45.1	8.71	35.4	8.18
OPT295-72-4-1YY	295	45.5	8.78	35.8	8.23
OPT300-72-4-1YY	300	45.6	8.85	36.1	8.30
OPT305-72-4-1YY	305	45.7	8.90	36.2	8.42
OPT310-72-4-1YY	310	45.8	8.79	36.4	8.51
OPT315-72-4-1YY	315	45.9	9.05	36.6	8.62
OPT320-72-4-1YY	320	46.2	9.08	36.9	8.68
OPT325-72-4-1YY	325	46.4	9.12	37.1	8.76
OPT330-72-4-1YY	330	46.6	9.15	37.5	8.80

Revision History

Revision	Date	Notes
1	6.14.12	Release
2	3.25.13	Added 270 W Bin Class, Added 1000 V UL.
3	4.19.13	Added 270, 315, 320, 325, 330 Bin Class
4	1.27.14	Clarified connector language
5	8.25.2014	Expanded Equipment Grounding section, Added 275 & 280 Bin Class