



Suniva Inc.
 5765 Peachtree Industrial Blvd
 Norcross, GA 30092
 Tel: 404-477-2700
techsupport@suniva.com
www.suniva.com/ourproducts.php

Suniva MVP Installation and Instruction Manual

Introduction

This manual provides safety and installation instructions for Suniva photovoltaic modules, herein referred to as module(s), with the followings model numbers:

- MVP2XX-60-5-401; Where XX could be 30 to 50 in increments of 5
- MVPXXX-72-5-401; Where XXX could be 270 to 300 in increments of 5

To maintain the safety of yourself and others, carefully read the entire installation and instruction sheet prior to installation and operation. System safety and proper design should be ensured by qualified personnel. Failure to comply with these instructions will invalidate the Suniva Limited Warranty for the module. For more information, please visit our website.

Safety

- Suniva modules produce electricity when exposed to light. To avoid electric shock and injury, completely cover the front of the module with an opaque material before making any electrical connections and disconnect the module from all electrical connections before any maintenance or cleaning.
- Only individuals trained in the principles of electricity and electrical equipment should install modules.
- Modules must be installed in a manner compliant with the National Electric Code (NEC) and all applicable standards and codes.
- Use properly insulated tools and appropriate protective equipment and work only in dry conditions.
- Protective gloves should be worn when handling modules to protect against sharp edges and burns.
- Do not artificially concentrate sunlight on the module(s).
- Do not install the modules in an area where flammable gas or material may be present.
- Do not remove any part installed by a qualified installer, or disassemble the module in any way.
- Use original packaging to transport and store module.
- Avoid excessive bending and twisting of the module.
- Do not exert excessive loads on the module. Do not step/stand on the module.
- Avoid wearing metallic jewelry when installing or handling the module to protect against electric shock.
- Do not leave the module unsupported or loosely fixed during or prior to installation and avoid installing during heavy winds.
- Do not attempt to repair a broken or damaged module, replace immediately to avoid fire danger and shock hazard. Use caution when handling as damaged modules may conduct electricity to the frame.

Product Information

- This solar module can be used in series and parallel array configurations or as a stand-alone system.
- For IEC installations: This module is certified to IEC 61730-1 and IEC 61730-2 for application Class A and is rated for use in systems operating at voltages greater than 50 VDC or 240 W, where general contact access is expected. And for Class A applications this module meets requirements of Safety Class II as defined by IEC 61140.

- The allowable operating temperatures range of the module is 185 °F to -40 °F (85 °C to -40 °C).

Serial Number

- The structure of the module serial number provides the following information:

Example: SJWSH00011103310017
 S-JWSH-0001 – 11– 03 – 31 – 0017
 A-BBCC-DDDD-EE-FF-GG-HHHH

A: Manufacturer; BB: Factory; CC: Factory Location
 DDDD: Engineering Number; EE: Year of Production; FF: Month of Production; GG: Date of Production; HHHH: 4 digit sequence 0 to 9999 for sequential production starting on each new day of production at 0001.

Electrical Characteristics

- See tables at end of installation manual for electrical parameters.
- The electrical characteristics are within ±10 percent of the indicated values of I_{SC} , V_{OC} , and P_{MAX} under standard test conditions; irradiance of 100 mW/cm², AM 1.5 spectrum, and a cell temperature of 25°C (77°F).
- Maximum series fuse rating is 15 A
- This module is rated for use in systems of up to 1000 V for TUV/IEC and 600 V for UL
- Under normal conditions, a photovoltaic module is likely to experience conditions that produce more current and/or voltage than reported at standard test conditions. Accordingly, the values of I_{SC} and V_{OC} marked on this module should be multiplied by a factor of 1.25 when determining component voltage ratings, conductor ampacities, fuse sizes, and size of controls connected to the PV output.
- Per NEC: “Refer to Section 690-8 of the NEC for an additional multiplying factor of 125 percent (80 percent derating) which may be applicable.”

Temperature Coefficients

Temperature Coefficients		
Power	$\gamma, P_{max} (\%/^{\circ}C)$	- 0.47
Voltage	$\beta, V_{oc} (\%/^{\circ}C)$	- 0.34
Current	$\alpha, I_{sc} (\%/^{\circ}C)$	+ 0.045
NOCT	C	45 +/- 2

Mounting Overview

- Mounting design and installation should be performed by trained professional and must conform to local codes.
- Select a site and configuration that maximizes direct sunlight exposure and eliminates or minimizes shadowing.
- Avoid small tilt angles to prevent the accumulation of dirt/debris along module edge.
- Improper mounting of the module(s) can lead to damage or injury and will void the warranty. Do not drill additional mounting holes into module frames. This will void the warranty.
- The module(s) should be fixed in a manner that withstands all expected loads, including those caused by wind, snow and ice. Verify by certified engineer.
- Orient the module junction box in such a way and provide clearance between the module frame and mounting surface to ensure that water cannot build up at the junction box and so the junction box does not contact the mounting surface.
- The module must be installed on a roof with appropriate fire resistance. Consult your local building authority or fire department to determine approved roofing materials.
- If the module is to be mounted to a roof of a building, the assembly must be mounted over a fire resistant roof covering suitable for the application. A slope less than 5 in/ft (127 mm/305mm) is required to maintain the fire class rating.

Mounting Instructions

- It is acceptable to mount this module using bolts or clamps to secure module to a structure on a roof, building or ground.
- Provide a minimum of 4 in (~100 mm) clearance between back of module and roof or ground or building, etc. when installing to ensure proper air flow.
- Allow for thermal expansion of the frames by providing a minimum of 0.25 in (or approximately 6 mm) spacing between modules.
- Any alternative configurations must be verified to meet load requirements.
 - This module has been tested to UL1703 for a design load rating of 30 lb/ft².
 - This module has been tested to IEC61215 for a design load up to 5400 Pa (113 lb/ft²)

Rail Mounting

- A supporting structure can be used to mount the modules at various tilt angles. See Figure 1 for recommend configuration. Ensure no dissimilar combinations of metals be used that when damp or wet could result in degradation of the materials and as a result create conditions that prevent the module from meeting installation requirements and instructions set forth in this manual.
- The frame of each module has eight (8) mounting holes. These are to be used to secure the module(s) to the supporting structure. Use an M8 bolt with a M8 flat washer beneath bolt head and an M8 lock washer between M8 nut and rail with a minimum of 88 in-lb (10 N-m) of torque to secure bolt. Use only stainless steel mounting hardware.
- For IEC 5400 Pa design load, use all 8 mounting holes.
- For IEC 2400 Pa design load or UL 30 lb/ft² design load use the set of four holes marked by distance C in Figure 1.
- It is recommended that the mounting rails must be within 1 in (2.54 cm) of the frame mounting holes (Figure 1) and run perpendicular to the length of the module.

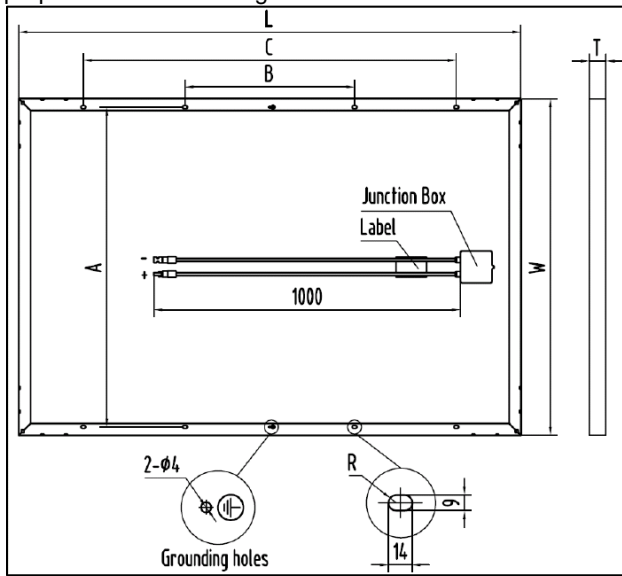

Model		L	W	T	A	B	C
MVPXXX-60 Series	in. (mm)	64.6 (1640)	39.1 (992)	2.0 (50)	37.1 (942)	33.9 (860)	53.5 (1360)
MVPXXX-72 Series	in. (mm)	77.0 (1956)	39.1 (992)	2.0 (50)	37.1 (942)	33.9 (860)	51.2 (1300)

Figure 1: Mounting/Grounding Hole Location

Grounding

- Ground the module in accordance with local requirements and NEC Article 250 where applicable. Size and earth ground conductor accordingly.

- Earth conductors should be large enough for let-through energy.
- Methods to secure earth wires to PV module frame should be mechanically sound to ensure electrical continuity at all times.
- When using a self-tapping screw to make bonding connection ensure at least two full threads engage in the metal.
- The following methods are certified for grounding the module.
- For Canada; Grounding method must comply with Safety Standard for Electrical Installations, Canadian Electrical Code, Part 1. CSA C22.1
- Attach the grounding conductor to the module frame through at least one of the two grounding holes on the module using the provided grounding kit, See Figure 1.

Installation of Grounding Hardware

Use of Tyco SolKlip Grounding Clip Assembly

The grounding clip manufactured by Tyco Electronics Corp. (Part number: 1954381-2) is UL listed and designed for module grounding applications using a solid 10 to 12 AWG un-insulated ground wire. It is attached to grounding hole on module frame, Figure 2, by an integrated 8/32 in screw. Place the grounding clip onto the frame, making sure that the screw straddles the grounding hole. Using a No. 2 cross-recessed screwdriver, turn the screw into the hole until the head is flush with the base and the base is flush with the frame, then tighten the screw with another 1/4 to 1/2 turn. Thread the hex nut onto the end of the screw, then using a 3/8-in. wrench, tighten the nut. Recommended torque is between 20 and 25 in-lb (2.3 and 2.8 N-m) for screw and nut. Insert the wire into the wire slot. Press down on both ends of the wire (the wire slot will cause the wire to form a slight curve). Manually, or using channel lock pliers, push the slider over the base until it covers the base. This will terminate the wire.

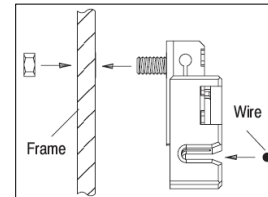

Figure 2: SolKlip Grounding Diagram

Wiring

- Connect modules using the supplied Tyco type connectors in series or parallel configurations.
- Only same type of connector shall be used in connections to ensure the reliability of the electrical connection.
- For conductor utilize suitable "Wet or Dry" type sunlight resistant cable (PV-Wire, or USE-2 type) with temperature rating of 90 °C or higher and sized 12 AWG or larger. Paralleled configurations may require greater wire size to accommodate increase current. Ensuring proper conductor sizing is the responsibility of the installer.

Junction Box

- Do not open the junction box or change inter-module wiring. All wiring connections are made in the factory and doing so may void the warranty.

Bypass Diodes

- 3 Schottky type bypass diodes are pre-assembled in each module.
- Do not uninstall these diodes.

Series/Parallel Configurations

- Series or Parallel configurations must be restricted to a maximum system voltage of 600 VDC (UL) or 1000 VDC (IEC).
- Voltage and current are temperature dependent and

systems should be designed to allow for variations due to local conditions.

- The voltage of modules in series connections will be equal to the sum of the individual voltages.
- The current of modules in parallel connections will be equal to the sum of the individual currents.
- Refer to the electrical characteristics for the values of I_{sc} and V_{oc} .

Series and Parallel interconnection restrictions

- At standard conditions (AM1.5G, 25 °C) the number of allowable modules in series is equal to the maximum system voltage divided by the Open Circuit voltage. The number of modules in series should be constrained by the expected minimum ambient temperature, module V_{oc} temperature coefficient (β), and module V_{oc} .
- Suniva recommends the following number modules connected in series to allow for a minimum ambient temperature - 40 C:

To prevent an open circuit voltage in excess of 1000 V:

For MVPXXX-60 Series modules: 21

For MVPXXX-72 Series modules: 18

To prevent an open circuit voltage in excess of 600 V:

For MVPXXX-60 Series modules: 12

For MVPXXX-72 Series modules: 10

- At standard conditions (AM1.5G, 25 °C) modules in parallel without fuse protection are not allowed.
- Suniva recommends that no modules be connected in parallel without over current protection. 2 or more modules may be connected in parallel with over current protection.

Over Current Protection

- Series or parallel connections of modules or strings must be provided adequate over current protection such as a recognized circuit breaker or fuse meeting minimum requirements listed in the Product Information section of this manual and be certified and properly rated. System design and protection for any series/parallel configuration must be verified by a certified engineer and is the responsibility of the system integrator as currents may exceed 1.25 times I_{sc} under some conditions.

Disconnection Under Load

- Do NOT disconnect or connect module under load.
- Modules will produce electricity even under low light conditions. Treat modules as if they are live electrical equipment.
- To avoid electric shock and injury, completely cover the front of the module with an opaque material and disconnect the module from all electrical connections before disconnecting or connecting module wiring.

Maintenance

Maintenance is recommended to ensure optimal performance:

- Depending on local conditions, periodically inspect and clean the surface of the module with water and a soft cloth or sponge when the modules surface becomes dirty and rain water is insufficient to remove dirt/debris.
- Never clean the modules during the middles of the day when the glass is hot to avoid injury.
- Never scratch or rub away any dirt when the modules are dry.
- Check the electrical and mechanical connections annually to ensure all the connections are secure, tight, clean and free of corrosion.

Disclaimer of Liability

Suniva does not assume responsibility and expressly disclaims liability for loss, damage or expense arising out in any way

connected with installation, operation, use or maintenance by using this manual. Suniva assumes no responsibility for any infringement of patents or other rights of third parties that may result from use of the module. No license is granted by implication or otherwise under any patent or patent rights. Suniva reserves the right to make changes to the product, specifications or this manual without prior notice.

Electrical Characteristics

For MVPXXX-60 Series modules ending in 401

Module ID	P_{MP} [W]	V_{OC} [V]	I_{SC} [A]	V_{MP} [V]	I_{MP} [A]
MVP230-60-5-401	230	36.75	8.5	28.67	8.02
MVP235-60-5-401	235	37.07	8.69	29.06	8.09
MVP240-60-5-401	240	37.54	8.9	29.55	8.12
MVP245-60-5-401	245	37.8	8.94	30.06	8.15
MVP250-60-5-401	250	38	8.98	30.4	8.22

For MVPXXX-72 Series modules ending in 401

Module ID	P_{MP} [W]	V_{OC} [V]	I_{SC} [A]	V_{MP} [V]	I_{MP} [A]
MVP270-72-5-401	270	43.03	8.34	34.80	7.76
MVP275-72-5-401	275	43.28	8.46	34.93	7.87
MVP280-72-5-401	280	43.93	8.57	35.23	7.95
MVP285-72-5-401	285	44.58	8.59	35.52	8.02
MVP290-72-5-401	290	44.82	8.82	35.76	8.10
MVP295-72-5-401	295	45.00	8.90	36.00	8.19
MVP300-72-5-401	300	45.25	8.99	36.20	8.29