

Suniva® ARTisun® Select Monocrystalline Photovoltaic Cells

Most Advanced Cell Performance

Suniva's ARTisun® Select monocrystalline cells are based on our most advanced technology, offering 18.2% - 19.4% efficiencies while continuing our dedication to low-cost manufacturing.

- Optimizes Suniva's proprietary manufacturing technology while maintaining low production costs
- Ensures positive cell tolerance by positive sorting
- Establishes Suniva as the leading manufacturer with uniform single-sided emitter using our exclusive processes for ion implantation in mass production

ARTisun® Select

Long-term Commitment to Quality

Suniva's uncompromising commitment to process control drives our reputation for superior quality, cell accuracy and the industry's best product performance.

- Proprietary texturing process contributes to best in class performance
- Rigorous quality management for maximum long-term performance and reliability
- Custom Manufacturing Executive System (MES) traceability for all cells and in-line process metrology

MADE IN
THE USA

Leading Scientists and Manufacturing Engineers

Our industry-renowned R&D scientists and PV engineers have spent their careers understanding and implementing what it takes to extract the maximum performance from each part of the cell to deliver superior power. Suniva combines intellectual property with collaborative equipment developments to create proprietary manufacturing that makes Suniva a leader in the solar industry.

American Innovation

Suniva's unique manufacturing processes and proprietary American PV technology results in high efficiency yields using low manufacturing costs to provide powerful cell performance. The result is a high efficiency solar cell made with low manufacturing costs, without compromising quality.



Suniva® ARTisun® Select Monocrystalline Photovoltaic Cells

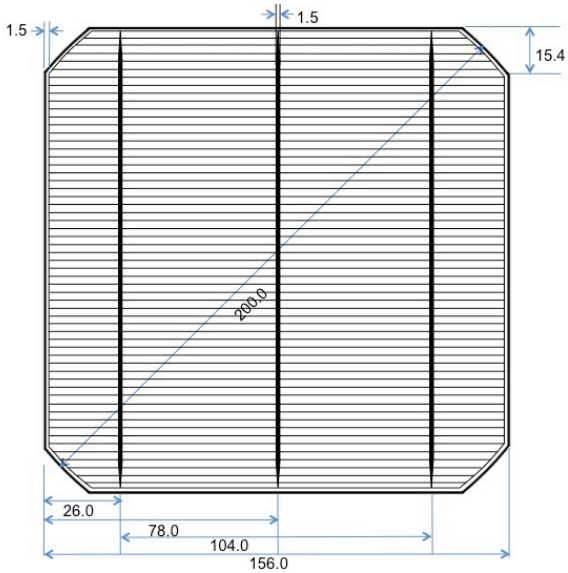

Scaled drawing (front of wafer)

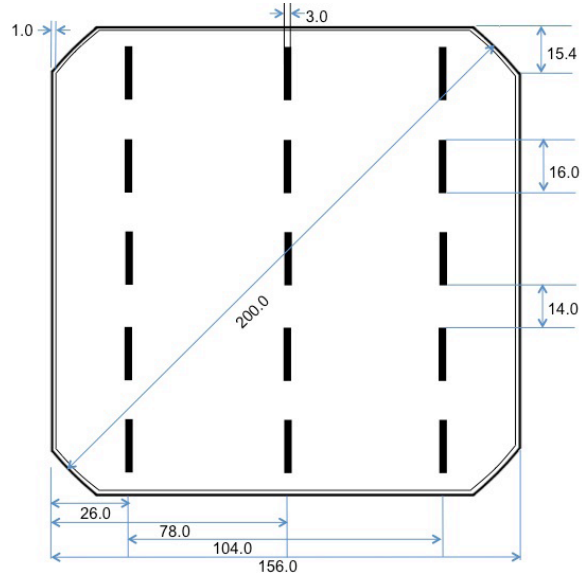

Scaled drawing (back of wafer)

Dimensions may vary by ± 0.5

Typical Cell Electrical Properties¹

ARTisun Select	18.20	18.40	18.60	18.80	19.00	19.20
Efficiency (%)	18.20-18.40	18.40-18.60	18.60-18.80	18.80-19.00	19.00-19.20	19.20-19.40
Power Pmp (W)	4.35-4.40	4.40-4.44	4.44-4.49	4.49-4.54	4.54-4.59	4.59-4.64
Max Power Current Imp (A)	8.29	8.34	8.39	8.44	8.49	8.54
Short Circuit Current Isc (A)	8.88	8.92	8.96	9.00	9.04	9.08
Max. Power Voltage Vmp (V)	0.527	0.530	0.533	0.535	0.538	0.540
Open Circuit Voltage Voc (V)	0.634	0.635	0.636	0.638	0.639	0.640

¹ All electrical parameters valid under Standard Testing Conditions (STC): Intensity - 1000 W/m²; Spectrum - AM1.5 Global; Temperature - 25°
 * Suniva recommends a maximum of 20 cells per bypass diode

Cell Temperature Coefficients

Parameter		Value
Voltage	$\beta(V_{oc})$	- 2.0mV/°C
Current	$\alpha(I_{sc})$	+4.2mA/°C
Power	$\gamma(P_{max})$	- 0.39%/°C

Wafer & Cell Specifications & Geometry

Parameter	Value
Crystal Growth Technique	Czochralski
Crystal Type	Monocrystalline
Crystal Orientation	<100>
Dopant Species	Boron, P Type
Cell Shape	Pseudo-square
Cell Size	156.0 \pm 0.5mm cut from 200 diameter \pm 0.5 mm
Cell Area	239 cm ²
Cell Thickness	200 \pm 40 microns
Cell Configuration	Front and Rear screen print; Aluminum Back Surface Field (BSF)
Cell Visual Appearance	Uniform dark blue (Silicon Nitride AR coating with fine pyramidal texture)

Suniva® reserves the right to change the data at any time.

Suniva ARTisun Select 3-Bus, 19.2% Solar Cell Current-Voltage (IV) as a Function of Insolation (W/m²)

